

T204

super-precision beam cell

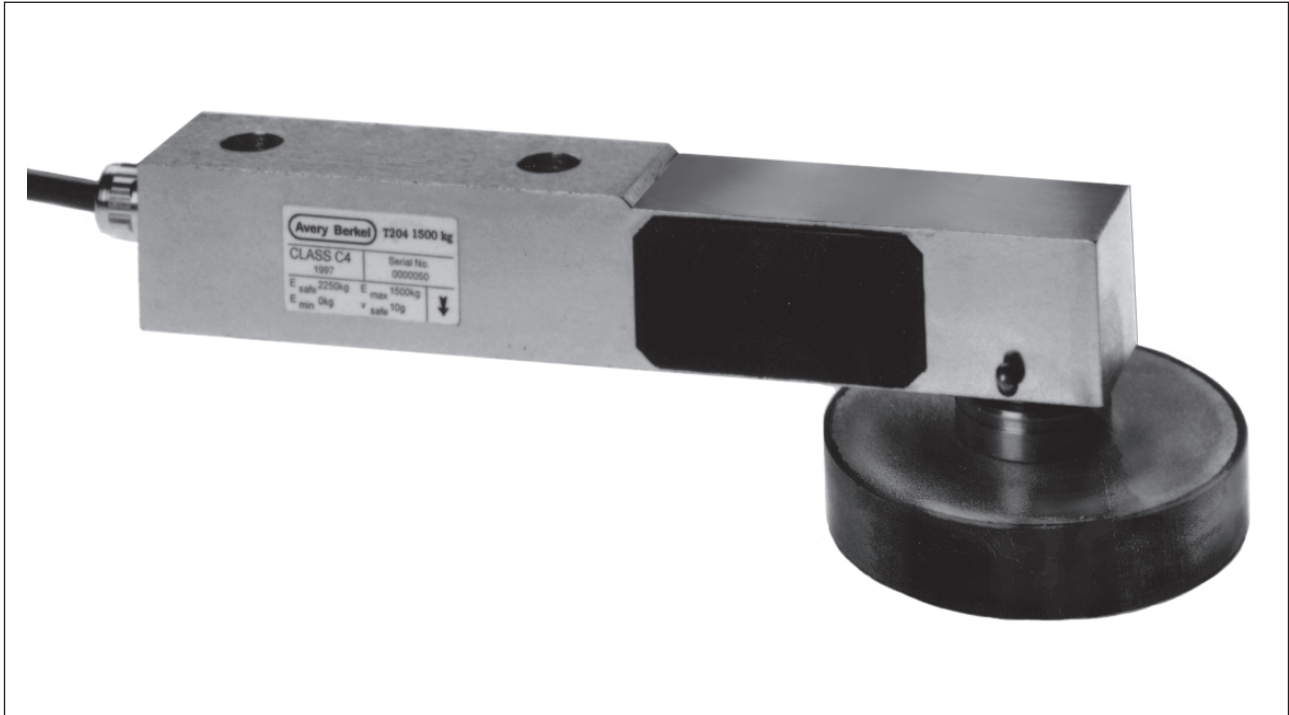

Description

A precision single-bridge shear beam force transducer manufactured in die steel with electroless nickel plating, designed for use in low profile platform scales and load cell in con-rod conversions of mechanical scales.

These transducers are mounted at one end and the load applied to the free end, via a through drilled hole or, with a blind hole machined to half the depth of the beam.

Capacities (E_{max})

750 kg, 1500 kg, 3000 kg.

Accuracy

4000d OIML R60.

Approvals

OIML R60 Certificate No. R60/1991-GB.97.02

Accuracy class C4.

$$V_{min} = E_{max} / 15000$$

Examples of Use

- Low profile platform scales.
- Load cell in con-rod conversions of mechanical scales.
- Hoppers, tanks and silos.
- Overhead track scales.
- Engine test stands.
- Dynamometers.

Special Features

- Exceptional accuracies.
- Low profile.
- Simple to install.
- Insensitive to side loads.
- Excellent repeatability.
- Small creep and hysteresis errors.
- Special version, approved for use in hazardous areas to CENELEC standards.

Specification

Resistance to Dirt & Moisture

Sealed to BS EN 60529:1992 Classification IP65 & IP67. Protection against total immersion in water for 30 minutes at a pressure corresponding to a 1 m head of water.

Enclosure

Strain gauges are encapsulated in butyl rubber and silicone sealant with an adhered neoprene rubber cover.

Neoprene has excellent weathering/ageing resistance and is resistant to oils, refrigerants and mild acids. It may be affected by aromatic and halogenated hydrocarbons.

Specification

Electrical Excitation (Recommended)	10V AC or DC
Electrical Excitation (Maximum)	15V AC or DC
Terminal Resistance (Input at 20°C)	410 Ω Nominal
Terminal Resistance (Output at 20°C)	350 Ω Nominal
Rated Output	1.75mV/V ± 0.1%
Zero Balance	± 1.0% Rated Output
* Combined Error	± 0.012% Rated Output
Repeatability	0.01% Rated Output
30 min Creep and Zero Return (OIML R60)	± 0.0125% Rated Output
Temperature Effect on Rated Output (-10°C to 40°C)	± 0.001%/°C
Temperature Effect on Zero Balance (-10°C to 40°C)	± 0.0025%/°C Rated Output
Overload Rating without affecting Performance	150% Rated Output
Ultimate Overload Rating	200% Rated Output
Maximum Permissible Side Load	50% Rated Output
Insulation Resistance (Minimum)	5,000 megohms
Deflection at Rated Output (750 kg, 1500 kg) (3000 kg)	0.3 mm Nominal 0.8 mm Nominal

* The combined error is the maximum deviation from the true value (straight line drawn from zero to full load) when either applying or removing the load.

Electrical Termination

6 Core standard lengths 4.0 m and 10.0 m.

Input: black -ve, green +ve

Output: red -ve, white +ve

Reference: blue -ve, brown +ve

Note:

6 core cables may be shortened without affecting performance.

Hazardous Area Version

Special version approved for use in hazardous areas to CENELEC standards.

DEMKO certificate 97D.122103.
EEx ia IIC T6.

$U_{max in}$	24 V
$I_{max in}$	400 mA
$W_{max in}$	1.3 W
L_{eq}	0
C_{eq}	0

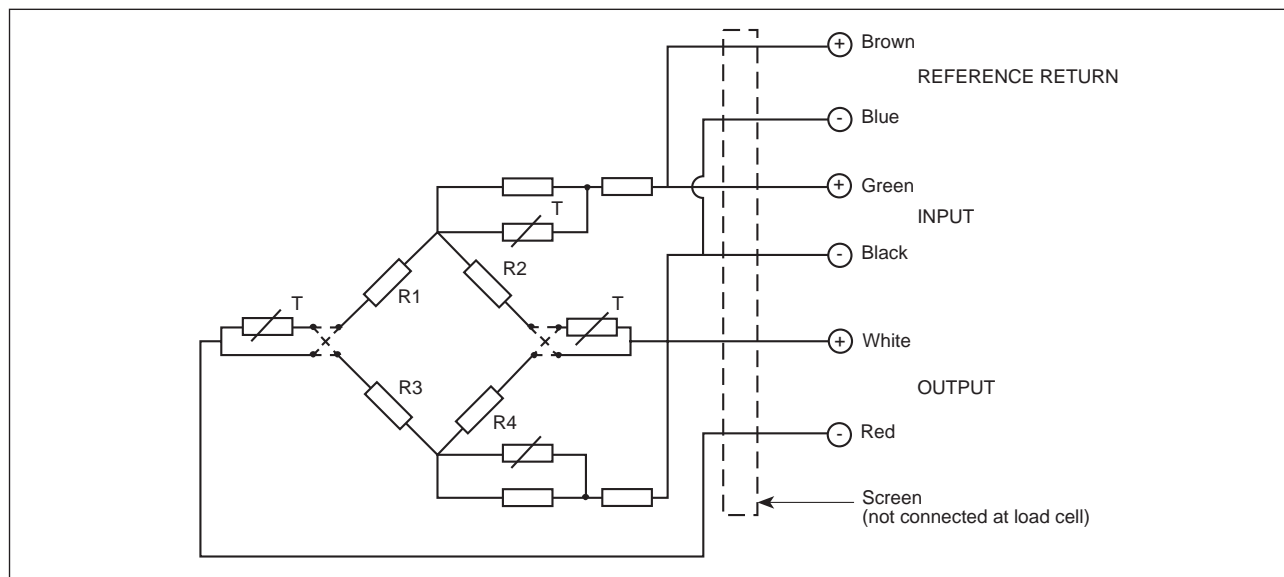

Circuit Diagram.

Applications

Mounting

The transducer should be mounted using high tensile bolts, grade 8.8 (minimum), and tightened to a torque of 70 Nm.

Loading

This transducer is designed to operate with loads applied to the free end of the beam only.

If loads in excess of the rated capacity are envisaged, then suitable adjustable overload stops should be provided and adjusted to operate between 100% and 150% of rated capacity.

Platform Feet

For platform applications, two types of self-aligning, height adjustable feet are available as accessories:

1. For standard weighing applications, a stainless steel and nitrile rubber foot for use with the Blind Hole version of the T204.

Nitrile rubber has good mechanical properties and is resistant to a wide range of petroleum oils and fluids. It may be affected by aromatic and halogenated hydrocarbons.

2. For precision weighing applications and/or where aggressive chemicals may be present, an all stainless steel rolling ball foot for use with the Through the Hole version of the T204.

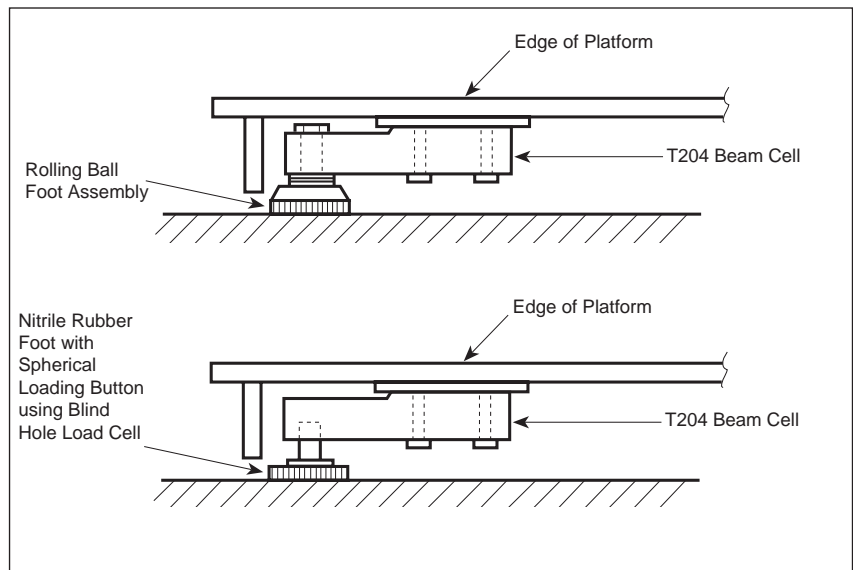
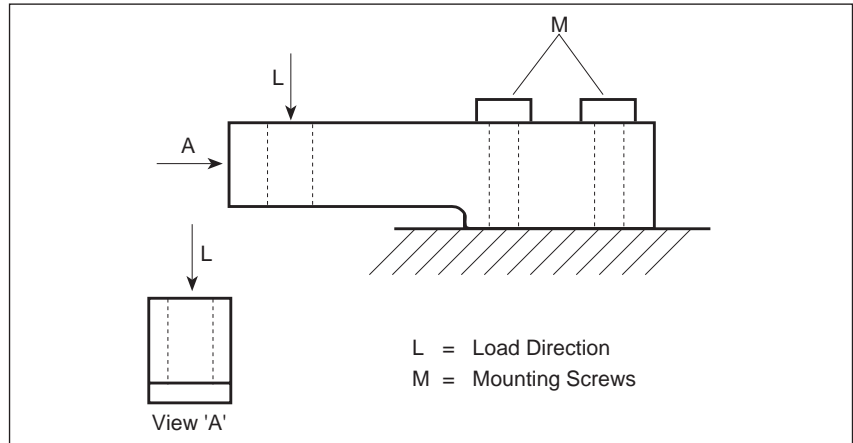

Loading example - Low Profile Platform Scale.

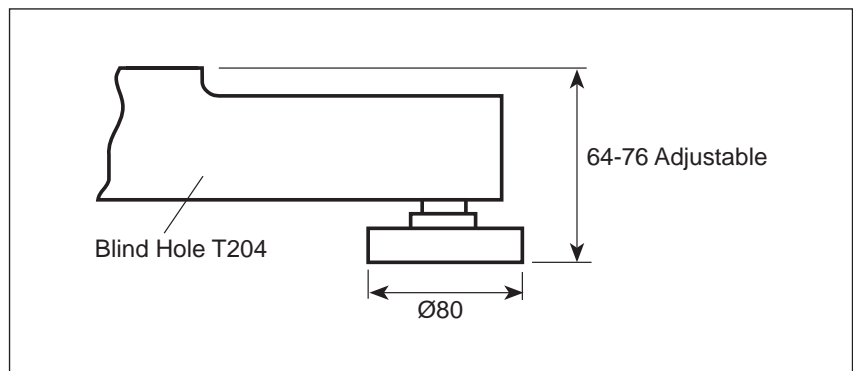

Stainless steel/nitrile rubber foot for standard applications.

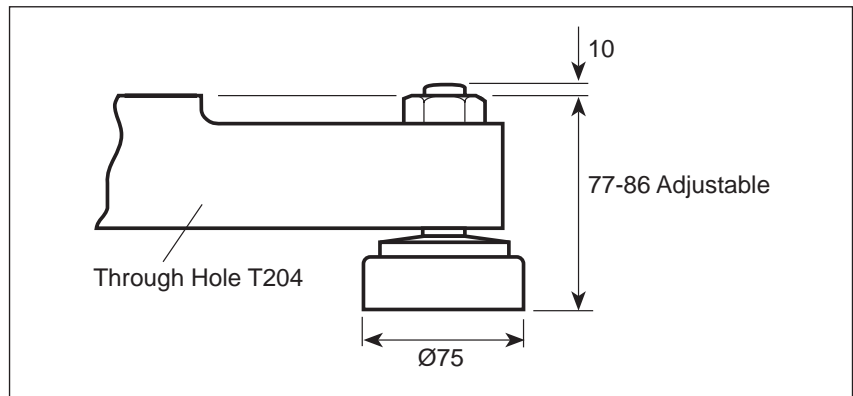

All stainless steel ball foot for precision applications.

Dimensions

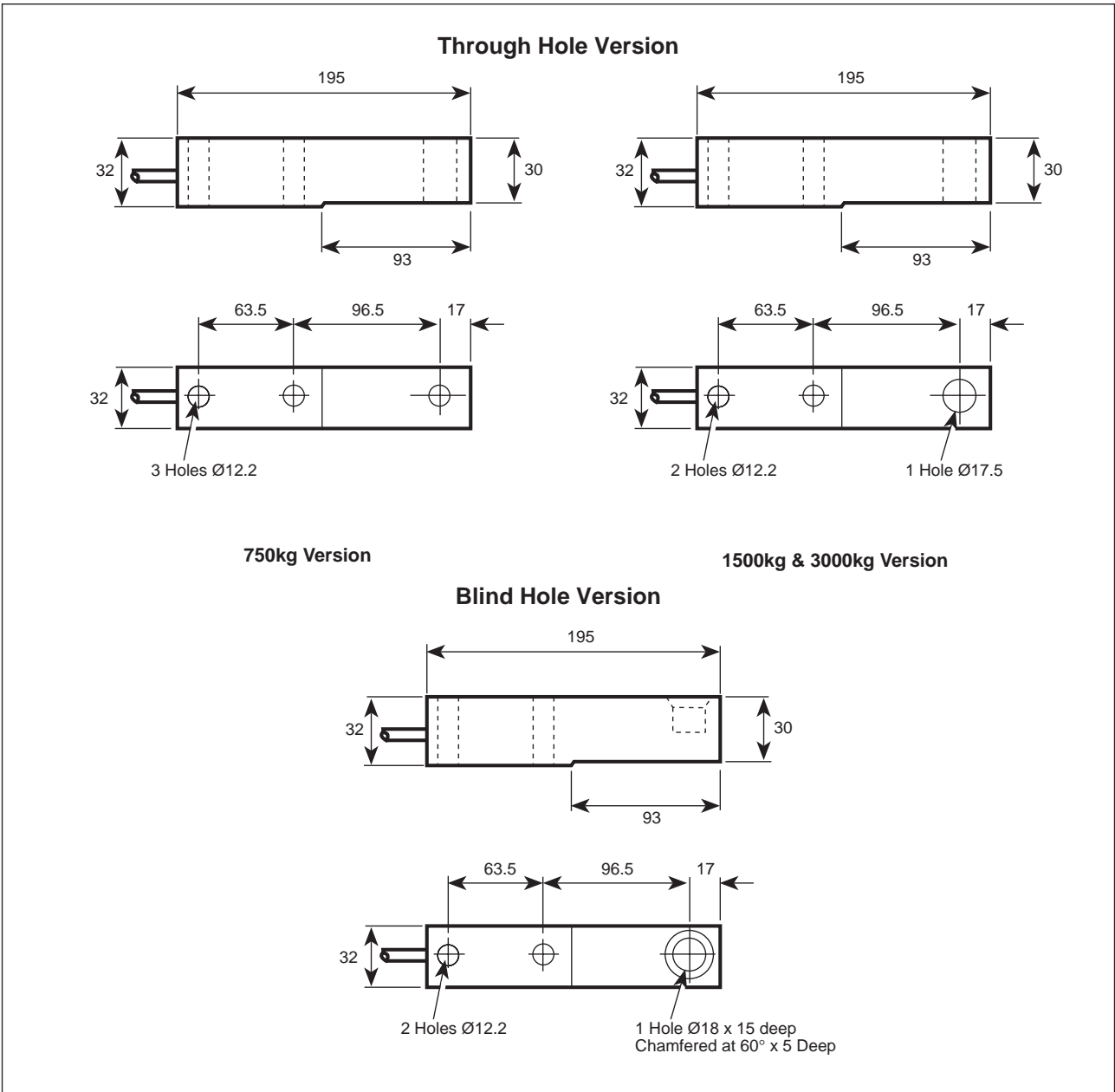

This brochure contains a general guide only of the product and shall not form part of any contract unless specifically agreed by Avery Berkel in writing in each case on the Order Acknowledgement. The specification of the products described herein may vary from time to time and may be altered without notice.

Your local distributor:



FM 01255



E mail: info@averyberkel.com
 Internet: <http://www.averyberkel.com>

Foundry Lane, Smethwick,
 West Midlands, England B66 2LP.
 Tel: +44 (0)870 90 34343 Fax: +44 (0)121-555 6062